

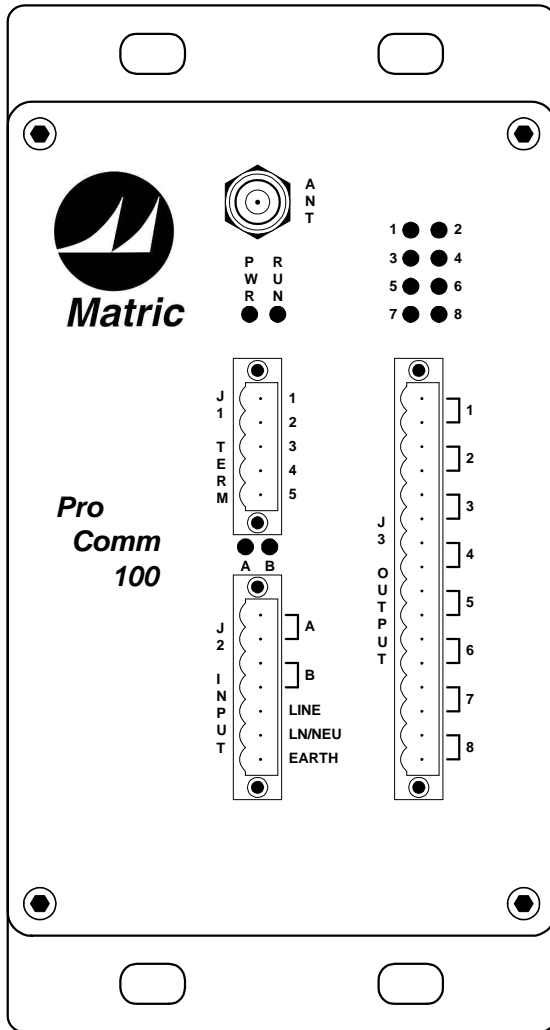

ProComm PC-100



Convenient wireless control is easily installed using a ProComm embedded control unit. The ProComm provides power and flexibility for new applications as well as a thoughtful space-saving package for upgrading existing systems.

ProComm controllers are ideal for many material handling and process control applications such as jib cranes, sifting grates, slurry barges, and belt controls.

The ProComm 100 is a radio receiver combined with a versatile power supply, a microprocessor based controller, and robust I/O capability. This highly integrated controller packs eight relay outputs, two discrete inputs, and one analog output into a rugged enclosure small enough to fit easily into a crowded electrical panel.

Consult our website for the latest models and features in the ProComm family of controllers.

SPECIFICATIONS:

- 8 isolated relay outputs, 120VAC, 6A, NO or NC
- Additional relay cards available (8 outputs each)
- 2 isolated discrete inputs, 120VAC/DC
- 1 analog output, 0-10VDC (+/-4%)
- RS232 serial port for programming
- 900MHz one way radio with 8 channels
- Operational range of 0 - 300 feet
- Output and input active indicators
- Power and data indicators
- 8 bit controller with 32K flash and CPU watchdog
- Powered by 100VAC to 240VAC, 50Hz or 60Hz
- Remote antenna mount up to 30 feet
- Operational temperature range of 0°C to +70°C
- Storage temperature range of -40°C to +85°C
- Logic customization available
- 8 inches X 4.125 inches X 4 inches, 3 LB
- Relay life rated at 1 million cycles assure reliable operation
- Rugged aluminum enclosure with panel mount flange
- Removable screw clamp connectors handle up to 12 gauge wire

APPLICATION:

The Process Communicator is a general purpose embedded controller that can be used in a wide variety of applications. The ProComm responds to any complete message received from operator handheld stations. This allows ProComm systems to support multiple operators. If operators attempt to operate equipment at the same moment, the RF messages will be contaminated and the ProComm will ignore both commands. The ProComm is designed to respond when data is received from an operator handheld station. Continuous communication is not supported and the lack of RF input is not considered an alarm condition.

Two systems are diagrammed in this section as examples of possible applications.

The first diagram shows the ProComm applied to a hydraulic control system. A pump motor is controlled along with two hydraulic solenoid valves. A TriggerPad handstation is shown as the operator's handheld station.

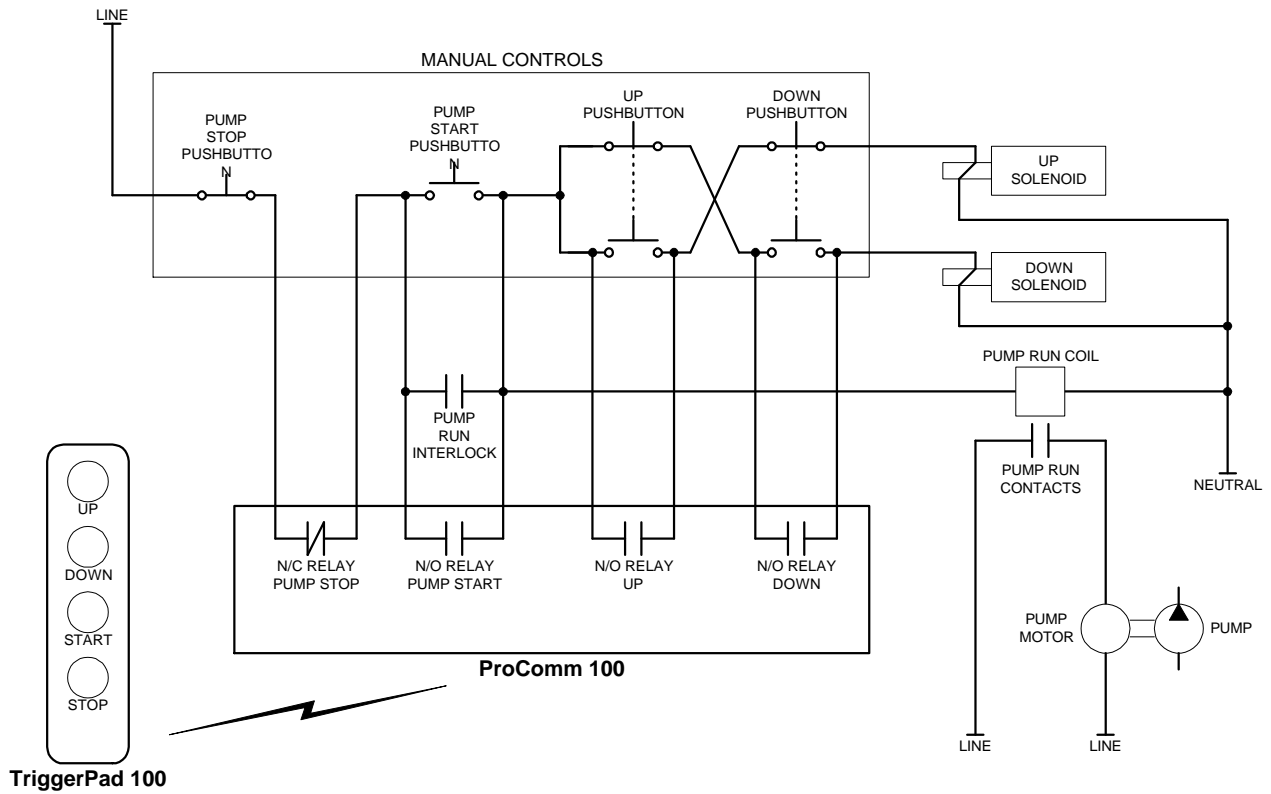

The second diagram shows the ProComm applied to a variable speed belt control system. Here the ProComm simply interfaces to the variable speed motor drive. A TriggerPad handstation is shown as the operator's handheld station.

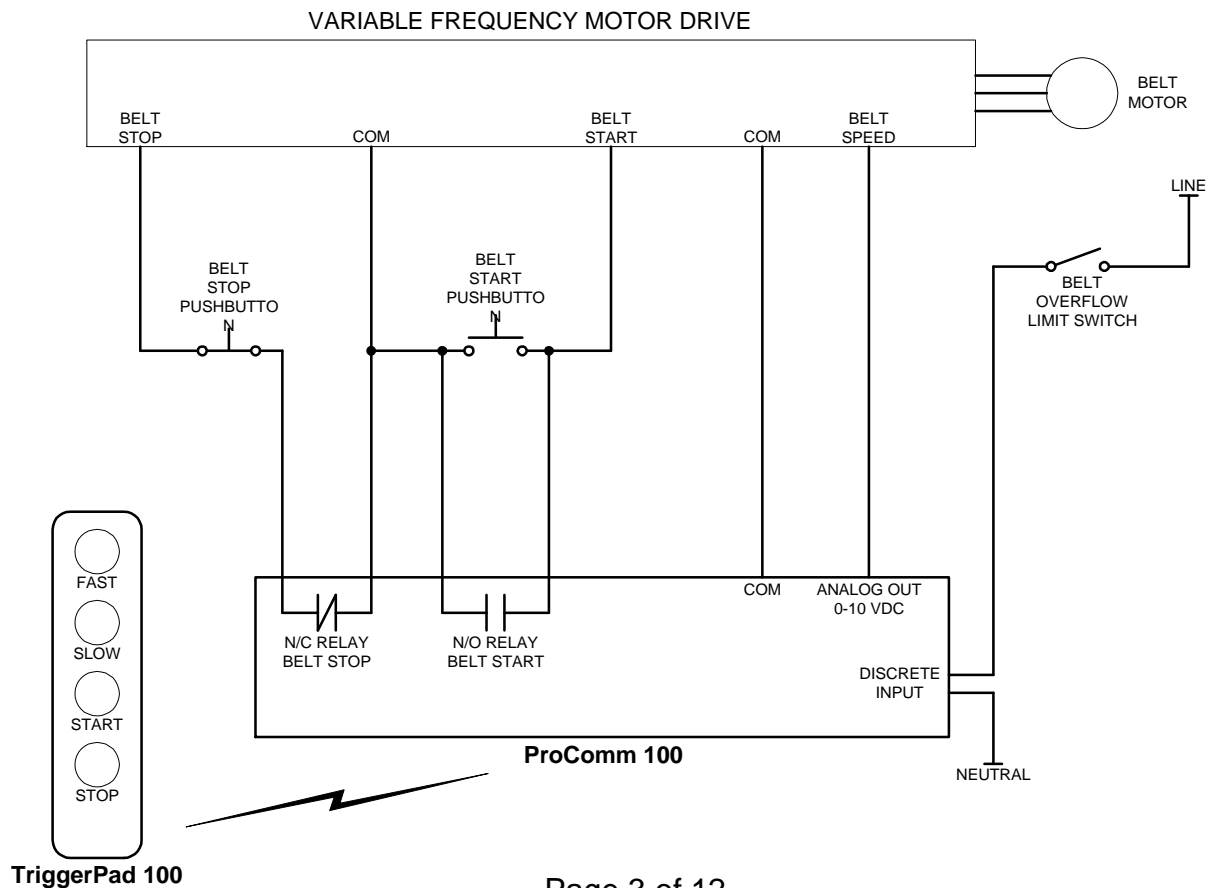

CONFIGURATION:

There are three aspects of the ProComm that require configuration.

- Radio Channel
- Relays Normally Open or Normally Closed
- Programming

Radio Channel Configuration

The ProComm supports eight channels to avoid interaction when multiple ProComm systems are employed in close proximity situations. The radio channel can be configured at the factory prior to shipment or by a technician in the field. See the configuration sheet to specify a channel for factory configuration.

Channel	Frequency
0	903.37 MHz
1*	906.37 MHz*
2	907.87 MHz
3	909.37 MHz
4	912.37 MHz
5	915.37 MHz
6	919.87 MHz
7	921.37 MHz

*Factory default channel selection

For safety reasons, on site radio channel configuration requires the following basic steps.

1. Power down and lock out any systems that could be operating at the frequencies shown above.
2. Set the TriggerPad channel. (See instructions below.)
3. Set the channel of the ProComm. (Refer to the appropriate receiver user manual, i.e. ProComm 100, for receiver configuration.)
4. Return processes and equipment to service.

Please note, to avoid accidentally duplicating channels, it is recommended that the default channel NOT be used in a multi-station application.

The following procedure will select the appropriate ProComm channel for use with any applicable Matric handheld transmitter.

1. Disconnect the ProComm from power and field wiring.
2. Connect a jumper between pins J1-2 and J1-3 of the TERM interface.
3. With no active radios in the frequency ranges shown above, apply power to the ProComm. The ProComm will begin scanning for an active channel frequency and channel selection message.
4. Activate the channel transmission signal from the handheld that will be used with the ProComm. Refer to the appropriate user manual (i.e. TriggerPad). The ProComm PWR indicator will flash when it recognizes the transmitter and sets the appropriate frequency.
5. To confirm proper operation, operate the handheld transmitter and note that the ProComm RUN indicator blinks while valid data is being received.
6. Remove power from the ProComm and remove the jumper from J1-2 and J1-3.
7. Reconnect wiring and power up configured system.

Relay Configuration

The eight ProComm relay outputs can be configured as either normally closed (n/c) or normally open (n/o). When a relay is configured as n/o, the relay contacts are open when the relay coil is not energized (such as during power off). Likewise, when a relay is configured as n/c, the relay contacts are closed when the relay coil is not energized.

The relay n/o or n/c configuration is performed at the factory according to customer specifications. See the configuration sheet to specify n/o or n/c for each ProComm relay output when placing a ProComm order. The default setting is for all eight relays to be configured as n/o.

Programming

The ProComm contains logic that maps handheld transmitter data and ProComm discrete inputs to relay and analog outputs. Programming of the control logic is performed at the factory according to customer specifications. See the configuration sheet for guidelines in specifying the functional logic of your ProComm application.

INDICATORS:

The ProComm 100 provides twelve red LEDs to indicate status and activity. The meaning of each LED is described below.

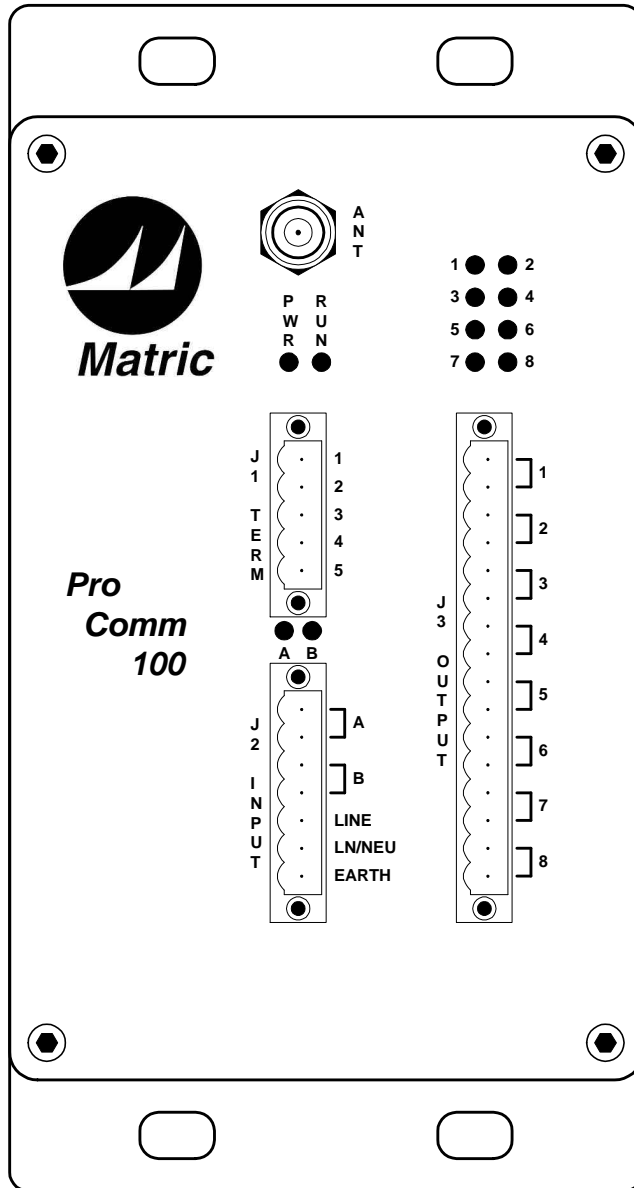

PWR

This indicator is located above the J1 (TERM) connector. When illuminated with a steady red light, the PWR LED indicates that power is being applied to the unit and the internal circuitry is operating properly. If communication between internal components is lost the ProComm will disable all outputs and the PWR LED will blink.

RUN

This indicator is located above the J1 (TERM) connector. When illuminated with a steady red light, the RUN LED indicates normal program operation. When communication is present from a transmitter using the proper channel, the RUN LED will blink.

A

This indicator is located above the J2 (INPUT) connector. When illuminated with a steady red light, the A LED indicates an input of 120VAC nominal applied between J2-1 and J2-2.

B

This indicator is located above the J2 (INPUT) connector. When illuminated with a steady red light, the B LED indicates an input of 120VAC nominal applied between J2-3 and J2-4.

1-8

This set of indicators is located above the J3 (OUTPUT) connector. When illuminated with a steady red light, each LED indicates an active coil on the corresponding relay. Actual relay output state depends on n/o or n/c configuration.

INSTALLATION:

The ProComm unit is designed for easy panel mount installation. Refer to the drawing below for mounting dimensions (all dimensions are in inches).

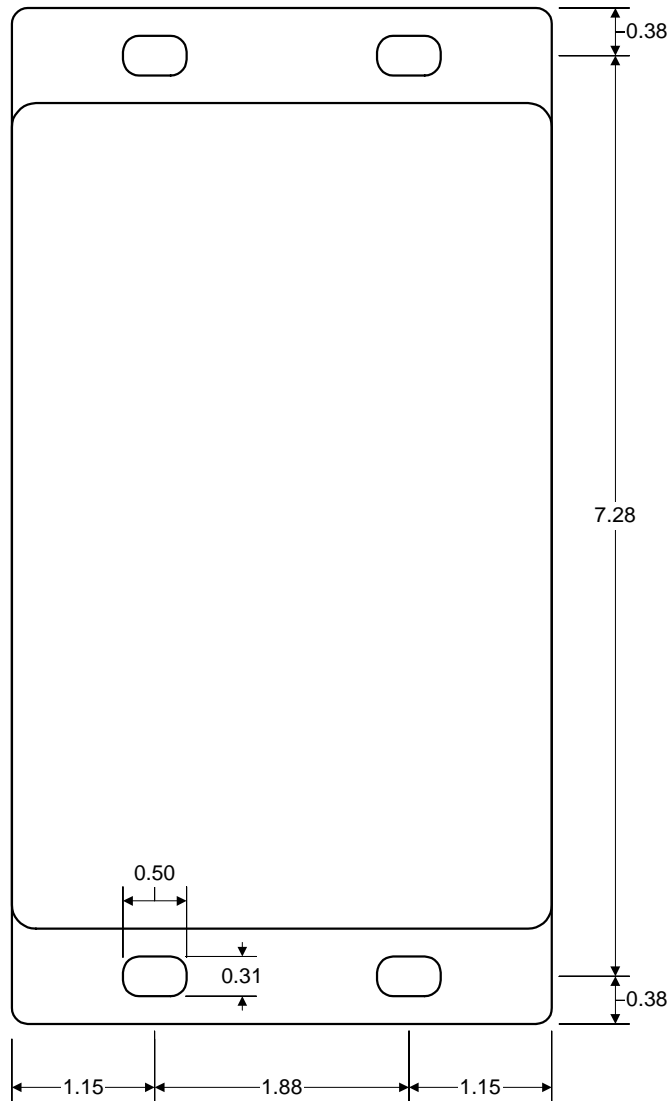

Removable screw terminals are provided for wiring power and I/O to the ProComm. The screw terminals can facilitate up to 12 gauge wire. Once wired, the terminals can be easily disconnected for maintenance or control panel layout changes.

NOTE: There is a replaceable internal 3.15 Amp fuse protecting the power supply of the ProComm.

INTERFACES:

Antenna

This BNC connector is for connection only to the provided antenna directly or via a 50 Ohm remote antenna cable.

Connector J1-1, 2, 3

This set of pins is used for serial communication with the ProComm. They are used for factory programming and should not be connected during normal operation. Pins J1-2 and J1-3 are used to change the radio channel selected. See the Configuration section for the details of radio channel selection.

J1-1	Factory programming initiation signal.
J1-2	Factory programming transmit signal.
J1-3	Factory programming receive signal.

Connector J1-4, 5

This pair of pins provides access to an analog output that can be used for speed control, chart recording, comparator thresholds, or other types of analog control signal. The actual operation of this output must be specified by the customer for factory programming.

J1-4	Digital to analog output signal. Provides 0-10VDC at a maximum of 30mA DC.
J1-5	Ground reference and shield for J1-4 (and all ProComm circuitry). Cabling to this pin must be routed away from noise sources.

Connector J2-1, 2, 3, 4

This set of pins provide two discrete AC inputs to the ProComm. A 120V AC nominal input applied between J2-1 and J2-2 will be indicated as input A. A 120V AC nominal input applied between J2-3 and J2-4 will be indicated as input B.

Connector J2-5, 6, 7

This set of pins constitutes the main power connection for the ProComm.

J2-5	Power supply input of Hot (120VAC operation) or Line (220VAC operation).
J2-6	Power supply input of Neutral (120VAC operation) or Line (220VAC operation).
J2-7	Power supply earth/chassis point. Connect for point of reference and path of noise suppression.

Connector J3-5, 6, 7, 8, 9, 10, 11, 12, 13, 14, 15, 16

Connector J3 is the interface for the 8 relay outputs of the ProComm. All relays are independent and can be configured as either normally open (n/o) or normally closed (n/c). All relays are rated at 6 amps continuous duty.

Output Number	Common Pin	Contact Pin (n/o or n/c)
1	J3-1	J3-2
2	J3-3	J3-4
3	J3-5	J3-6
4	J3-7	J3-8
5	J3-9	J3-10
6	J3-11	J3-12
7	J3-13	J3-14
8	J3-15	J3-16

PLACEMENT:

The ProComm 100 is an FSK radio receiver that operates in the 902-928 MHz band. Eight channels are provided for separation in adjacent applications. Multiple transmitters may be active on separate channels so long as an adjacent channel's signal does not enter the receiver at a level exceeding the rejection capability of the receiver. The effective rejection capability of the ProComm is dependent upon RF factors that vary from application to application. The rejection capability in a particular application may be determined through trial and error or through a comprehensive site assessment.

A site assessment should be performed before any new radio system is introduced into an operating environment where there are potential safety hazards. A thorough site assessment of an area will discover active radio frequencies that could lead to contention and their sources. Matric can arrange a site assessment at a customer's request.

For optimal performance, the antenna for the ProComm should be mounted vertically, away from solid objects, and in the most visible line of sight from the normal transmitting area. The ProComm 100 should be connected directly to an antenna or via coaxial cable to an antenna mounted within 30 feet of the ProComm unit. A remote antenna mounting kit is available to assist with achieving the most effective antenna location and position. If remote antenna mounting is used, route coaxial cable away from noise.

SERVICE:

Matric product support includes a responsive Customer Service department and a skilled Aftermarket Services department. Should your Matric product require servicing, contact Matric's Customer Service department at 800.462.8742. You will be given an MR number to include with your returned product that will expedite processing.



Matric

2099 Hill City Road

Seneca, PA 16346

814-677-0716

www.matric.com

Manual ProComm v3.doc

Doc No: 185-0040

Copyright 2002, Matric

Printed in USA, 11/04